

AC Output1

9 kW	60 Hz, 1800 RPM, 1 Ph, 1.0 PF, 120-240 V/37.5A, 120 V/75A
Optional	Three Phase with 0.8 PF
Voltage regulation	±1%

Lugger L773L Engine

Type	Vertical inline 3 cylinder diesel
Displacement	69 in ³ (1.13 ltr)
Bore/Stroke	3.03/3.19 in (77/81 mm)
HP @ RPM	15/1800 12/1500
Exhaust outlet	1.25 inch (31.75 mm) OD

Approx. fuel use

1800 RPM @ full load ²	0.93 gph (3.52 lph)
1800 RPM @ half load ²	0.51 gph (1.93 lph)
1500 RPM @ full load ²	0.72 gph (2.72 lph)
1500 RPM @ half load ²	0.37 gph (1.4 lph)

Installation Data & Weight

Fuel inlet and return	1/4 inch NPT
Exhaust Outlet	1 1/4 in (31.75 mm)
Approximate dry weight	556 lbs (252 kg)

1. Based on SAE J1995 and ISO 3046.

2. Actual fuel consumption will vary depending on operating conditions.

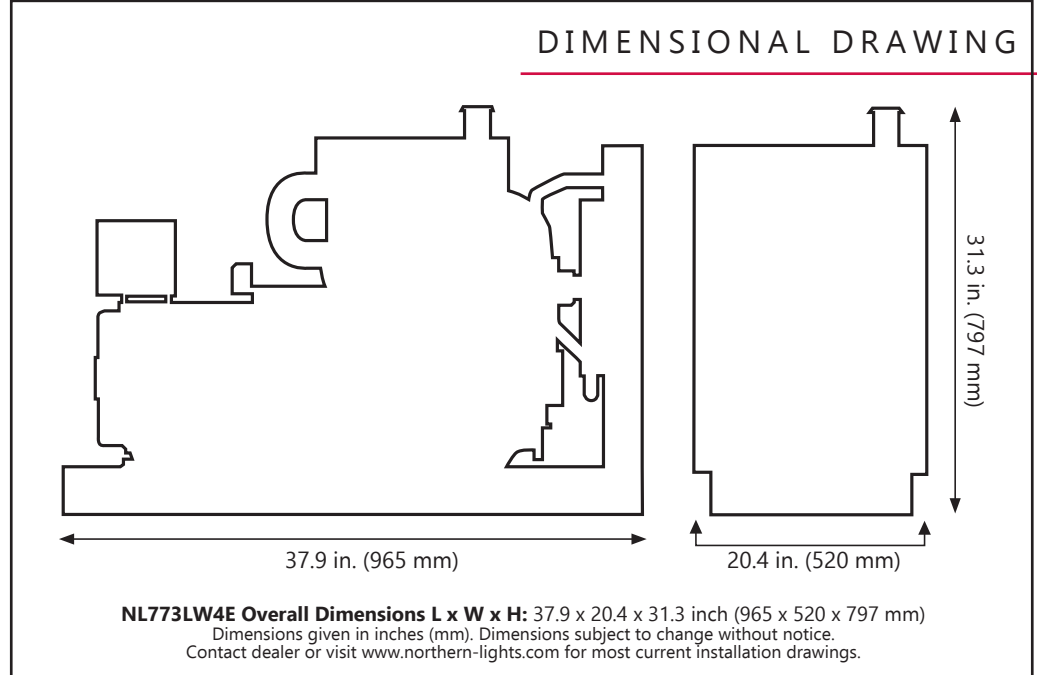

NL773LW4E FEATURES AND BENEFITS

ENGINE BLOCK

- Four cycle, 3 cylinder, liquid cooled, naturally aspirated, overhead valve, industrial-duty diesel.
- Indirect injection with glow plugs for fast cold weather starts.

COOLING SYSTEM

- Liquid-cooled with radiator and pusher cooling fan. Steel radiator shroud and fan guard protects the radiator and operator.

SELF-VENTING ELECTRICAL FUEL SYSTEM

- Electrical fuel system for safe, economical function.
- In-block inline pump.
- Stop solenoid controls the fuel rack - not throttle - to eliminate speed variance and linkage issues.
- Engine speed governed to 5% for close AC frequency control.
- Pintle fuel injectors with replaceable tips lower service cost.
- Large spin-on fuel filter.
- Flexible fuel lines routed to fuel manifold for easy tank connectivity.

LUBRICATION SYSTEM

- Pressure lubricated. Gerotor oil pump.
- Full flow, spin-on oil filter with bypass.
- 5 qt. (4.9 ltr) oil capacity for better lubrication.

INTAKE AND EXHAUST

- Meets US EPA Tier IV emission requirements for cleaner air.
- Large, replaceable air filter protects engine in dusty environments.
- Unit mounted residential muffler.

DC ELECTRICAL SYSTEM

- 12 volt system includes starter motor, battery charging alternator with solid state voltage regulator and DC circuit breaker.
- Standard, unit mount S-1B control panel has engine hour meter, start-stop switch with run light and preheat switch.
- Standard safety shutdowns for low oil pressure and high coolant temperature.
- Dual panel relays and quick disconnect harness plug-ins. With optional Y-harness and 10, 20 or 40 foot harness extensions, allows up to six remote control panels, up to 100 feet from the set.

AC GENERATOR

- Northern Lights, direct coupled, brushless AC generator is maintenance free. 4 lead, 1 phase, 1.0 pf, 50 or 60 Hz output. 12 lead-3 phase is optional. Conservative heat rise rating: 95°C/50°C ambient.
- Automatic Voltage Regulator is powered by dedicated AC winding for true 300% short circuit capability. Quick ±1% RMS no load to full load voltage regulation. AVR has circuit breaker protection.
- Generator features high quality, Class "H" epoxy insulation, accessible diodes, over-sized bearing and junction box for wiring.
- High air flow from integral fan keeps generator running cool.

SPECIAL FEATURES

- Welded steel frame provides rigid support and ease of installation.
- Enhanced fan guard for improved operator safety.
- Four centerbonded mounts isolate vibration.
- Long life, blue enamel paint finish.
- Full load testing at factory ensures trouble-free operation
- Operator's and parts manuals provided with each set.
- Custom shipping crate and carton.

**TIER
4**